

Valve proving system VPS 504 Series S06 (120Vac) Series S05 (24Vdc)

DUNGS[®]
Combustion Controls

Approvals:

VPS 504 S06 (120Vac) is:

CSA Certified

- File # 1637485
- CSA Requirement No. 4-01 (for USA)
- Technical Information Letter R-15 (for Canada)



UL Recognized

- File # MH17004



FM Approved

- File # J.I. 3004006



New York City Accepted

- File # MEA 57-05-E

VPS 504 S05 (24Vdc) is:

CSA Certified

- File # 1637485
- CSA Requirement No. 4-01 (USA)
- Technical Information Letter R-15 (Canada)



EC Type Certificate

- CE-0085 AP 0808



Commonwealth of Massachusetts Approved Product

- Approval code G1-1107-35
- Valve Proving System

Codes and Standards:

This product is intended for installations covered by but not limited to NFPA 86, NFPA 85, Swiss Re (formerly IRI), or CSA B149.3.

DUNGS is an ISO 9001 manufacturing facility.

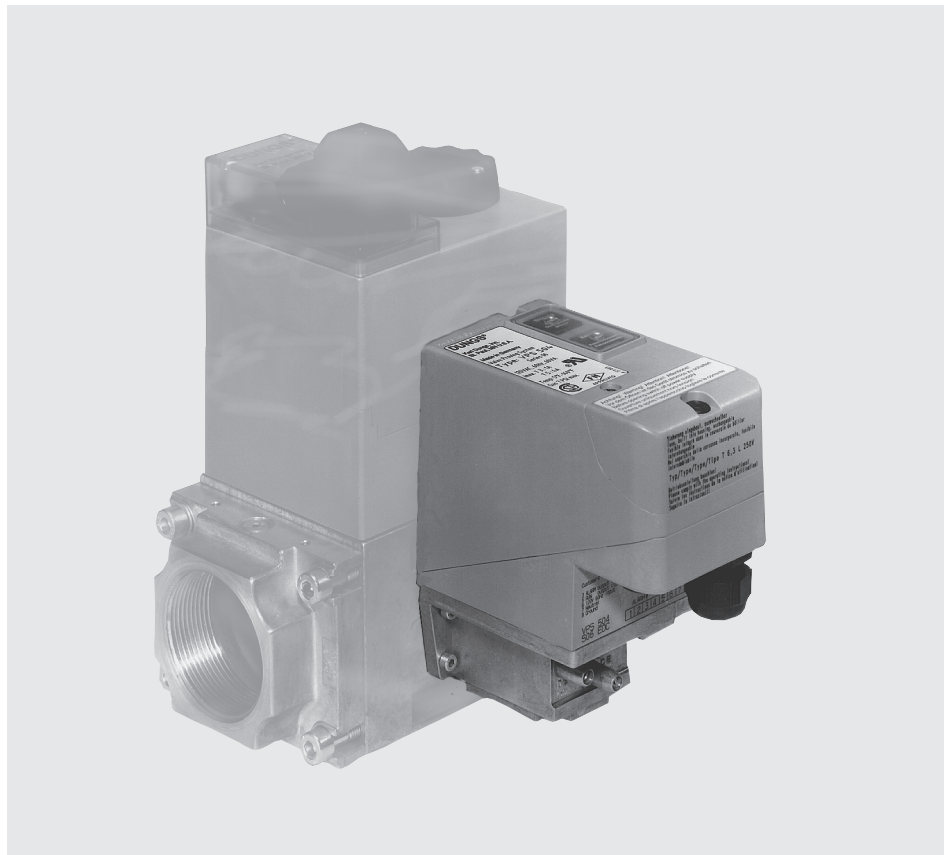

Description

The VPS 504 is a valve proving system for DMV series automatic valves. It verifies that both safety shutoff valves in a gas train are fully closed before a system start-up or after system shutdown when wired and interlocked to a suitable flame safeguard control. The VPS will halt the start-up sequence to a burner if it detects an open automatic shutoff valve, thus preventing ignition under potentially dangerous conditions.

- Release Signal Timing: min. 10 s, max. 26 s.
- Maximum test volume 0.14 ft³.
- "RUN" or "ALARM" condition is indicated by an LED.
- Electrical connection at screw terminals via 1/2" NPT conduit connection.
- Detectable leakage rate (each valve): 0.2 to 1.4ft³/h. See graph on page 2.

- No field adjustments or settings required.

Application

The VPS 504 is recommended for industrial and commercial heating applications. Some authorities having jurisdiction accept the VPS in lieu of "proof of closure" when integrated with the preignition system and/or in lieu of a vent valve when it checks the valves at start up and shut down. It can also be used as a valve seat tightness check when used within its capabilities.

The VPS is suitable for natural gas, propane, air, and inert gases. Not suitable for butane gas.

Specifications

Max. operating pressure	7 PSI (500 mbar)
Max. Body pressure	15 PSI (1 bar)
Electrical ratings (+10%/-15%)	110 - 120 Vac / 60 Hz for S06 series or 24Vdc for S05 series
Switch Output Rating	Series S06 is Run T5: 4 A res, 2 FLA @ 120 Vac & Alarm T3: 1 A res, 0.5 FLA @ 120Vac. S05 is Run TB: 4 A @ 24Vdc & Alarm TS: 1 A @ 24Vdc.
Power ratings (consumption)	Test period: 60 VA In operation: 17 VA
Enclosure rating	NEMA Type 12
Electrical connection	Screw terminals with 1/2" NPT conduit connection
Operating time	100% duty cycle, max. 20 test cycles/h
Materials in contact with gas	Housing: Aluminium Rubber components: NBR-based rubber
Ambient operating temperature	+5 °F to +140 °F (-15 °C to +60 °C)
Mounting position	Mounts directly to DMV via mounting screws (included with VPS) upright vertical to horizontal
Test volume	max 0.14 ft ³
Release Signal Timing	~ 10 s for test volume < 0.05 ft ³ > 10 s (max. 26 s) for test volume > 0.05 ft ³
Detectable leakage rate (each valve)	< 1.76 ft ³ /h
Detectable leakage through both valves (detectable leakage to the burner)	0.2 to 1.0 ft ³ /h (the 1.0 ft ³ /h represents the worst case scenario, which occurs only if the inlet pressure is 7 PSI and each valve leaks 0.88 ft ³ /h).

LEAK DETECTION LIMIT

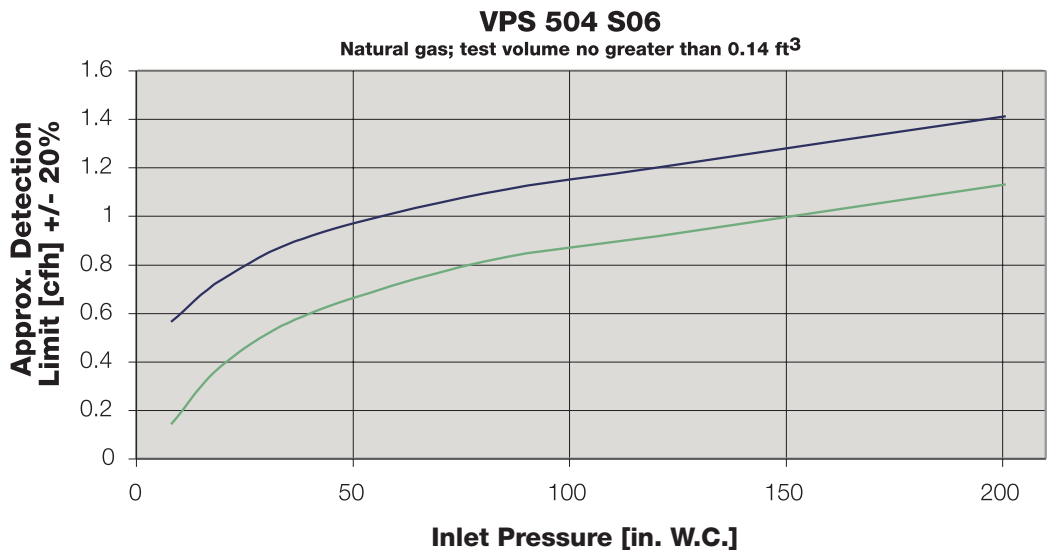

— **Maximum Limit**
— **Minimum Limit**

NOTE: Leak detection limit depends on inlet pressure and gas density.

To obtain approx. detectable leakage through both valves, divide value in chart by 1.6. **2 ... 6**

VPS 504 sectional diagram

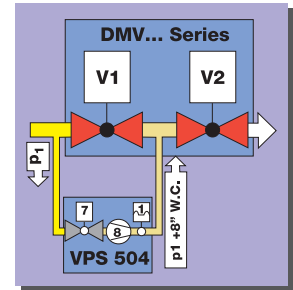
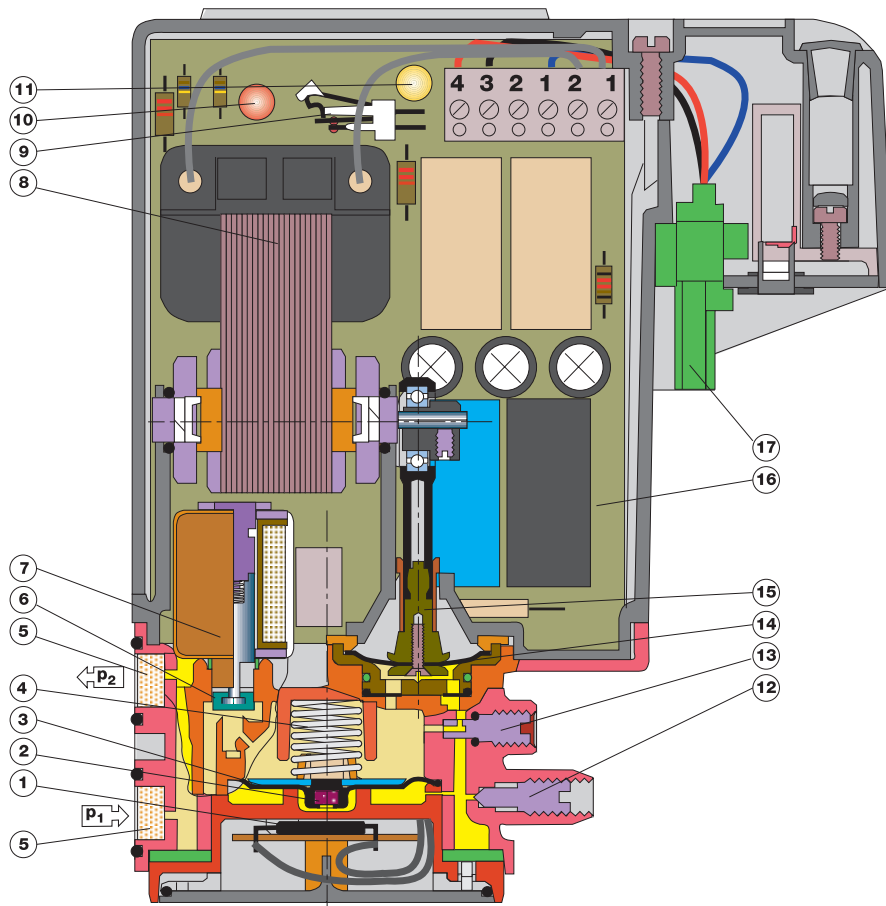

1	Hall Sensor	8	Pressure pump	15	Pump linkage
2	Solenoid	9	Reset switch	16	PWB
3	Pressure switch diaphragm	10	Alarm lamp	17	Terminal block
4	Compression spring	11	Run lamp		
5	Filter	12	Inlet test nipple (p_1)		
6	Safety valve anchor (V3)	13	Outlet test nipple (p_2)		
7	Safety valve coil	14	Pump diaphragm		

Functional description

The VPS proves the integrity and the effective closure of the valve seats by pumping gas from upstream of the main safety valve to the volume between the two safety shutoff valves and detecting leakage. The VPS proves the valves as soon as power is applied. Valve proving can also occur prior to each start-up, after normal shut-down, and after safety shut-down when the VPS is integrated with the CM 100 or CM 101 control module. When the VPS is integrated with the CM 100 or CM 101, Swiss Re (formerly IRI) would allow the VPS to be used in lieu of a vent line.

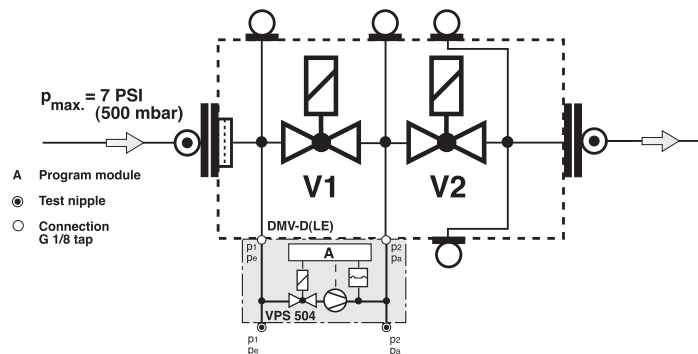

Release period t_F

Time from the beginning of the test cycle until the "RUN" T5 contact is energized. The release period of the VPS depends on test volume and input pressure:

$$\left. \begin{array}{l} V_{\text{Test}} < 0.05 \text{ ft}^3 \\ p_1 > 8 - 200 \text{ in. W.C.} \end{array} \right\} t_F \approx 10 \text{ s}$$

$$\left. \begin{array}{l} V_{\text{Test}} > 0.05 \text{ ft}^3 \\ p_1 > 8 - 200 \text{ in. W.C.} \end{array} \right\} t_F > 10 \text{ s}$$

t_F max. ≈ 26 s

Test period is the pumping time of motor pump.

Test volume V_{Test}

Volume between V_1 and V_2

$$V_{\text{Test max. VPS 504}} = 0.14 \text{ ft}^3$$

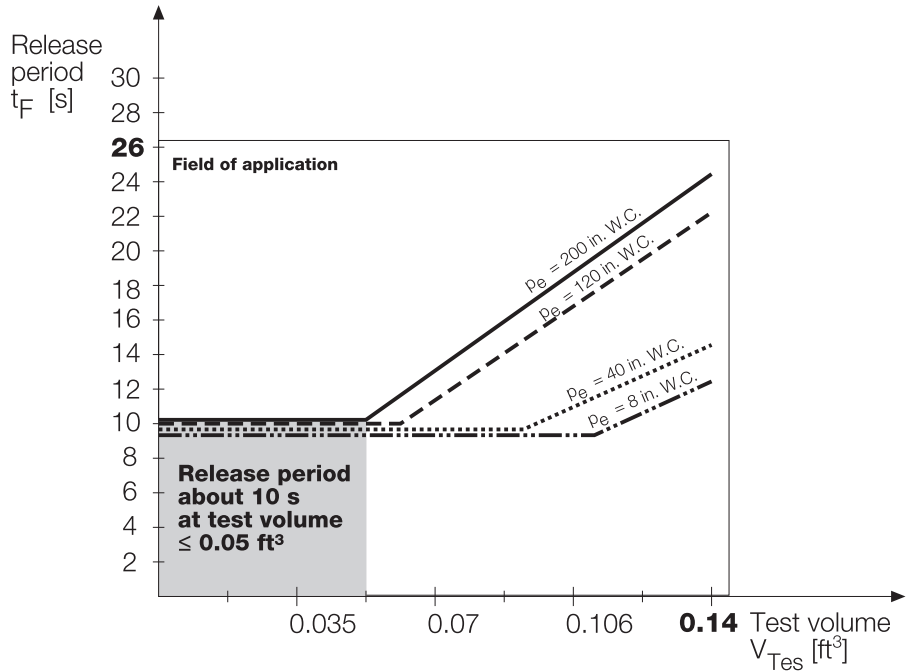

Program Sequence

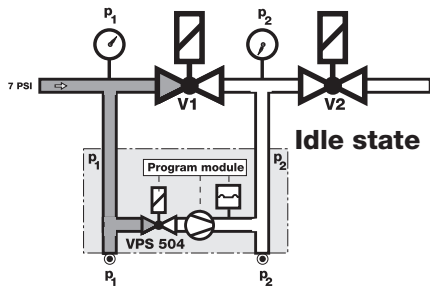

Idle state: Valves 1 and 2 are closed.

In the case of short-term voltage failure during test or burner operation, an automatic restart is performed.

Valve proving: The internal pump pumps gas pressure from upstream the first safety valve, p_1 , to the volume between the two safety valves. The gas pressure between the two safety shut-off valves, p_2 , increases approx. 8 in. W.C. above p_1 .

Operation

VPS pump remains off. "RUN" contact remains energized, and both valves are open.

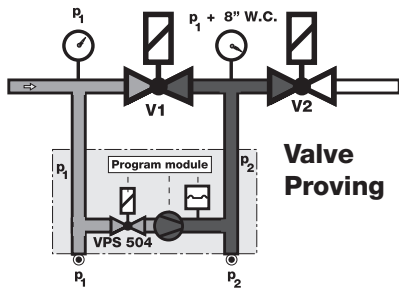

During the test period, the internal differential pressure switch monitors the pressure between the two safety valves.

If p_2 increases approx. 8 in. W.C. above p_1 , the motor pump is switched off (end of test period) as no leak is detected. The contact "RUN" (T5) is energized after 26 s max. and the yellow signal lamp lights continuously. (For 24Vdc models, terminal B is energized)

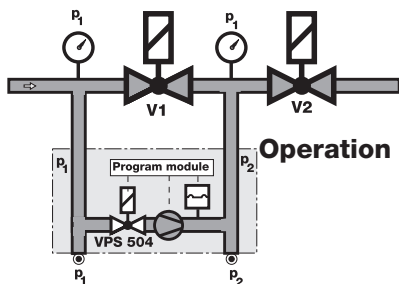

If p_2 does not increase approx. 8 in. W.C. above p_1 , the motor pump is switched off (end of test period) as a leak is detected. The contact "ALARM" (T3) is then energized after about 26 s, and the red signal lamp lights continuously. (For 24Vdc models, terminal S is energized)

The release time (10 - 20 s) depends on the test volume (max. 0.14 ft³) and input pressure (max. 200 In. W.C.)

Program flowchart

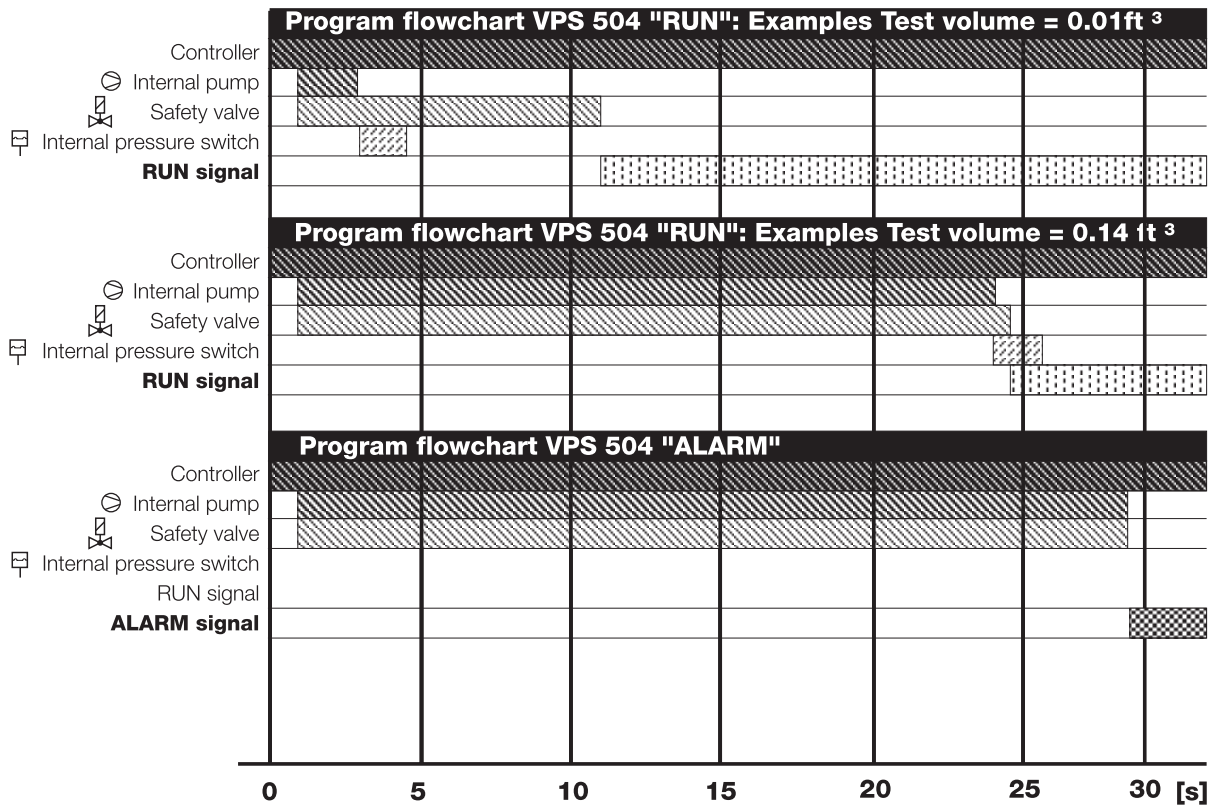

Electrical connection

1/2 in. conduit connection to screw terminals below cover in housing (see Dimensions VPS 504).

Operating voltage for S06 series is 120 Vac / 60 Hz ONLY.

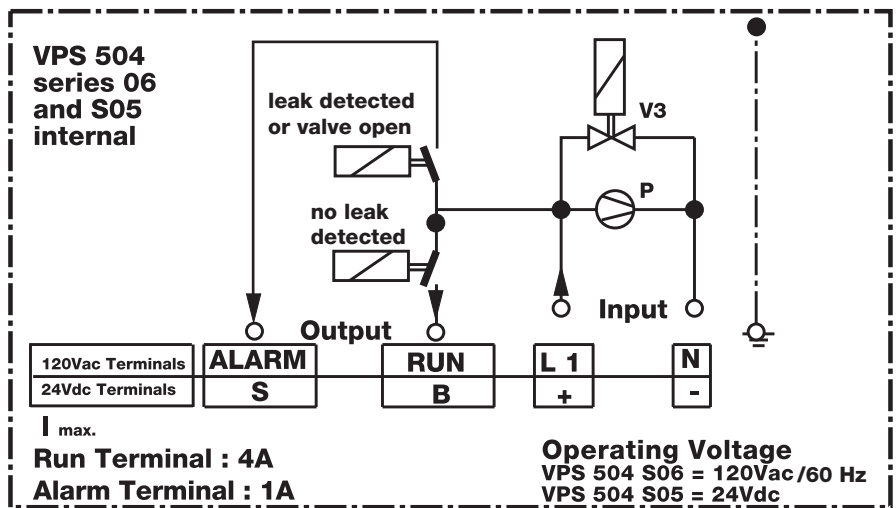

Accessory: CM 100 and CM 101

The DUNGS CM 100 and CM 101 incorporate the relays and logic necessary to operate the VPS 504 S06 on a system start up and after shutdown when wired and interlocked with a suitable flame safeguard control. When the VPS is integrated with the CM 100 or CM 101, Swiss Re (formerly IRI) would allow the VPS to be used in lieu of a vent line.

