

Safety Shutoff Valves

MVD/6 Series

MVDLE/6 Series

DUNGS®
Combustion Controls



Normally closed safety shutoff valve with the following approvals.

UL Listed

- UL 429
- File # MH16727

CSA Certified

- ANSI Z21.21 CSA 6.5
- Marked C/I
- File # LR 112901

FM Approved

- Class 7411
- File # JI.OV9A8.AF

Commonwealth of Massachusetts Approved Product

- Approval code G3-0106-191
- Gas Safety Shutoff Valve

US and Canadian Models

- MVD 505/6-MVD 530/6
- MVDLE 205/6-MVDLE 230/6
- 1/2 in. NPT - 3 in. NPT

Codes and Standards:

This product is intended for installations covered by but not limited to NFPA 86, NFPA 37, NFPA 160, ANSI Z83.4/ CSA 3.7, ANSI Z83.18/CSA 4.9, ANSI Z21.13, CSD-1, UL 795, UL 2200, CAN1-3.1, CGA 3.2, CSA 3.8, or CSA B149.3.

DUNGS is an ISO 9001 manufacturing facility.

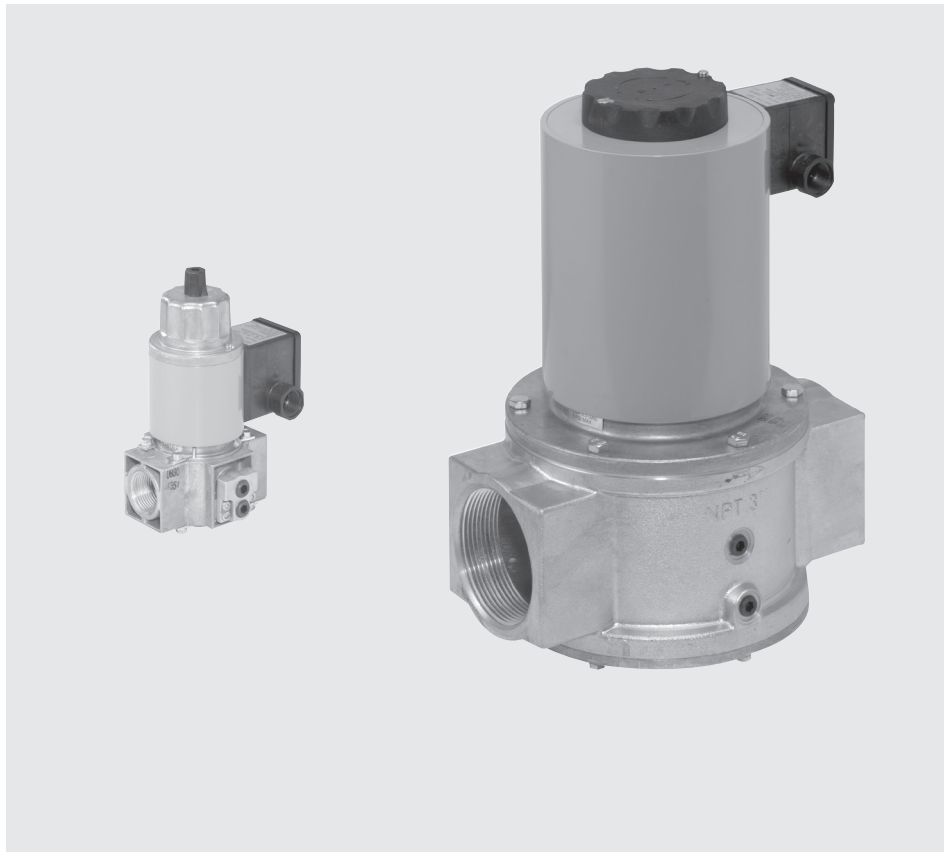

Description

The MVD/6 and MVDLE/6 series are electrically operated normally closed, automatic safety shutoff valves for gas burners and gas appliances.

- Closing time <1s.
- Max. operating pressure up to 7 PSI (500 mbar) on MVD/6
3 PSI (200 mbar) on MVDLE/6
- Max. close off pressure 15 PSI (1000 mbar) on all models
- MVD/6: fast opening/fast closing and maximum flow adjustment
- MVDLE/6: slow opening with adjustable initial lift, fast closing and maximum flow adjustment
- 120 VAC/ 60 Hz in all models,
24 VAC/ 60 Hz (in some models)
- 1/2" NPT conduit connection

- Optional field installable visual indicator (VI) or CPI 400 with indication lamps and SPDT interlock switch for valve position.
- Reliable, quiet operation, and rugged.



Application

The MVD/6 and MVDLE/6 safety shutoff valves are recommended for industrial and commercial heating applications that require one safety shutoff valve or two safety shutoff valves in series. These safety shutoff valves are suitable for use with natural gas, propane, butane, air and inert gases.

MVD	Normally closed automatic safety shutoff valve, fast opening, fast closing. Adjustable max. flow.
MVDLE	Normally closed automatic safety shutoff valve, slow opening, fast closing. Adjustable initial lift. Adjustable max. flow.

Specifications

Pipe thread (NPT)	1/2" 3/4" 1" 1 1/4" 1 1/2" 2" 2 1/2" 3"
Max. operating pressure	MVD is 7 PSI (500 mbar) / MVDLE is 3 PSI (200 mbar), see page 3
Max. body pressure	15 PSI (1000 mbar)
Max. close off pressure	15 PSI (1000 mbar)
Electrical ratings (-10 % to +15 %)	120 VAC, 24 VAC (available in some models) / 60 Hz; see page 3 and 4
Power ratings	Refer to type overview page 4
Enclosure ratings	NEMA 12
Electrical connection	Screw terminals with 1/2" NPT conduit connection
Operating time	100 % duty cycle
Cycle Rate and Cycle Life	1,000,000 cycle life for MVD when cycled no faster than 100 cycles/hr 500,000 cycle life for MVDLE when cycled no faster than 20 cycles/hr
Closing time	< 1 s
Opening time (to max. flow)	MVD < 1 s MVDLE Adjustable to approx. 10 to 20 s at 70 °F
Initial lift adjustment	MVDLE only - 0 to 70% of total flow; 0 to 35% of stroke
Max. flow adjustment	Adjustable from <10 to 100 % of total flow; <10 to 100 % of stroke
Materials in contact with gas	Aluminium, steel, brass / Seals: NBR-based rubber
Ambient temperature rating	See also page 3
Installation position	Safety shut off valve from vertically upright to horizontal
Test ports	Two 1/4" NPT upstream and two 1/4" NPT downstream ports
Gas strainer (standard)	Installed in the housing upstream (23 mesh)
Position indication (order separately)	CPI 400 with indication lamps and SPDT interlock switch or Visual indicator (VI)
Valve proving system (requires two safety shutoff valves in system)	Type VDK 200, mounts externally using valve side ports or pipe "T"s.

Approvals	Model	Temperature Rating	MOPD (PSI)**	Max. Close Off (PSI)	Electrical Ratings (Volts / Hz)
 UL 429	MVD	-20 °F to 120 °F	7	7	120/60 (+10% -15%)
	MVDLE	-20 °F to 120 °F	3	7	120/60 (+10% -15%)
	MVD	-20 °F to 120 °F	7	7	24/60 (+10% -15%)*
	MVDLE	-20 °F to 120 °F	3	7	24/60 (+10% -15%)*
 APPROVED FM 7411	MVD	-20 °F to 120 °F	7	15	120/60 (+10% -15%)
	MVDLE	-20 °F to 120 °F	3	15	120/60 (+10% -15%)
	MVD	-20 °F to 120 °F	7	15	24/60 (+10% -15%)*
	MVDLE	-20 °F to 120 °F	3	15	24/60 (+10% -15%)*
 C US ANSI Z21.21/ CSA 6.5 C/I	MVD	-20 °F to 120 °F	5	5	120/60 (+10% -15%)
	MVDLE	-20 °F to 120 °F	2	2	120/60 (+10% -15%)
	MVD	-20 °F to 120 °F	5	5	24/60 (+10% -15%)*
	MVDLE	-20 °F to 120 °F	2	2	24/60 (+10% -15%)*

* 24VAC available in some models (See page 4)

** Maximum Operating Pressure Differential

**Type MVD
sectional drawing**

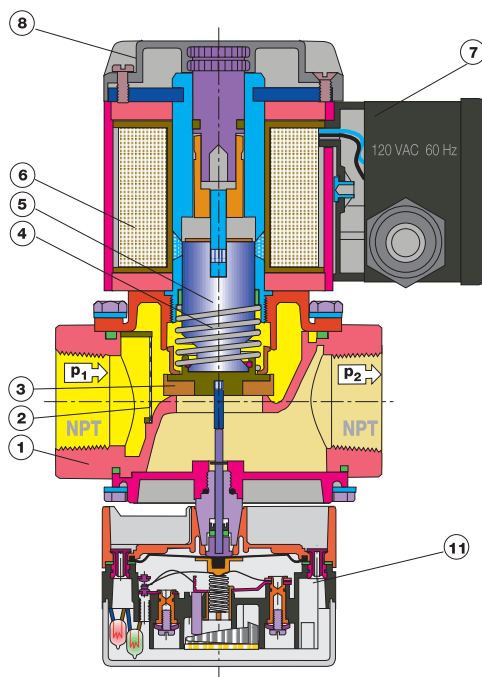

**Type MVDLE
sectional drawing**

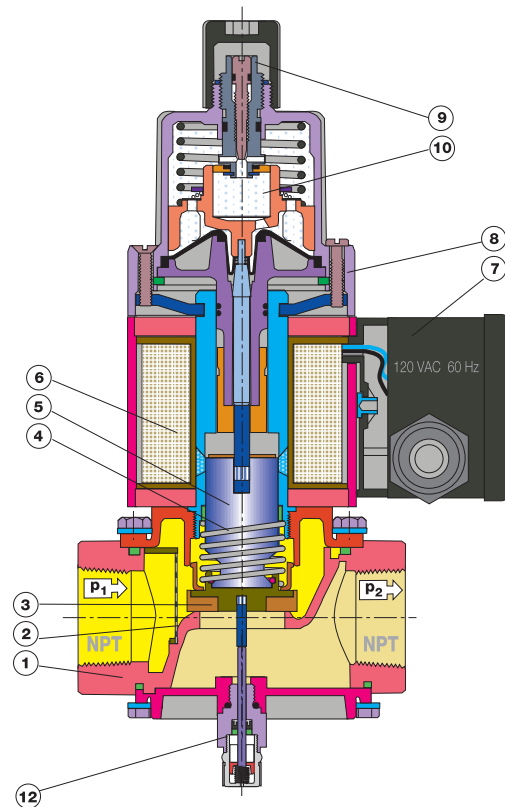

- | | | | | | |
|---|----------------|----|---------------------------------|----|-----------------------------------|
| 1 | Housing | 6 | Solenoid | 11 | CPI 400 position interlock switch |
| 2 | Strainer | 7 | Electrical connection | 12 | Visual indicator (VI) |
| 3 | Valve disc | 8 | Max flow adjustment | | |
| 4 | Closing spring | 9 | Initial lift adjustment MVDLE/6 | | |
| 5 | Plunger | 10 | Hydraulic brake MVDLE/6 | | |

Valve Type	Order No.	Size (NPT)	P _{max.} ** [VA] Inrush and Full Load	Dimensions [inch]					Weight [lbs] [kg]
				a	b	c	d	e	
MVDLE 205/6*	216-870	1/2"	15	1.97	2.95	5.31	2.76	6.10	2.43
	217-320*			50	75	135	70	155	1,10
MVDLE 207/6*	216-589	3/4"	25	2.95	3.94	6.50	3.15	7.48	5.62
	217-321*			75	100	165	80	190	2,55
MVDLE 210/6*	216-590	1"	25	2.95	4.33	6.50	3.54	7.68	6.06
	217-322*			75	110	165	90	195	2,75
MVDLE 212/6	217-250	1 1/4"	60	3.74	5.91	8.07	4.57	9.65	9.70
				95	150	205	116	245	4,40
MVDLE 215/6	217-631	1 1/2"	60	4.52	5.91	8.07	4.57	9.65	12.13
				115	150	205	116	245	5,50
MVDLE 220/6	217-632	2"	60	4.52	6.69	8.07	5.12	9.84	13.67
				115	170	205	130	250	6,20
MVDLE 225/6	216-633	2 1/2"	80	4.52	9.06	11.61	6.50	13.78	25.13
				115	230	295	165	350	11,40
MVDLE 230/6	217-251	3"	90	5.12	10.43	14.21	7.87	16.97	38.14
				130	265	361	200	431	17,31
MVD 505/6*	217-641	1/2"	15	1.97	2.95	3.54	2.76	4.45	2.20
	217-640*			50	75	90	70	113	1,00
MVD 507/6*	217-606	3/4"	25	2.95	3.94	5.31	3.15	6.30	5.29
	217-435*			75	100	135	80	160	2,40
MVD 510/6*	217-436	1"	25	2.95	4.33	5.31	3.54	6.50	5.73
	217-437*			75	110	135	90	165	2,60
MVD 512/6	217-438	1 1/4"	60	3.74	5.91	6.89	4.57	8.27	11.91
				95	150	175	116	210	5,40
MVD 515/6	217-439	1 1/2"	60	3.74	5.91	6.89	4.57	8.27	11.91
				95	150	175	116	210	5,40
MVD 520/6	217-440	2"	100	4.53	6.69	6.89	5.12	9.25	19.40
				115	170	175	130	235	8,80
MVD 525/6	217-441	2 1/2"	80	5.12	9.06	8.46	6.50	10.63	31.97
				130	230	215	165	270	14,50
MVD 530/6	217-442	3"	100	5.91	10.43	11.22	7.87	13.94	55.11
				150	265	285	200	354	25,00

* Designates model is also available in 24VAC/60 Hz. Part Number also shown.

** Inrush current and full load current have the same VA rating.

Dimensions inch (mm) (MVDLE shown. See page 4 for all values)

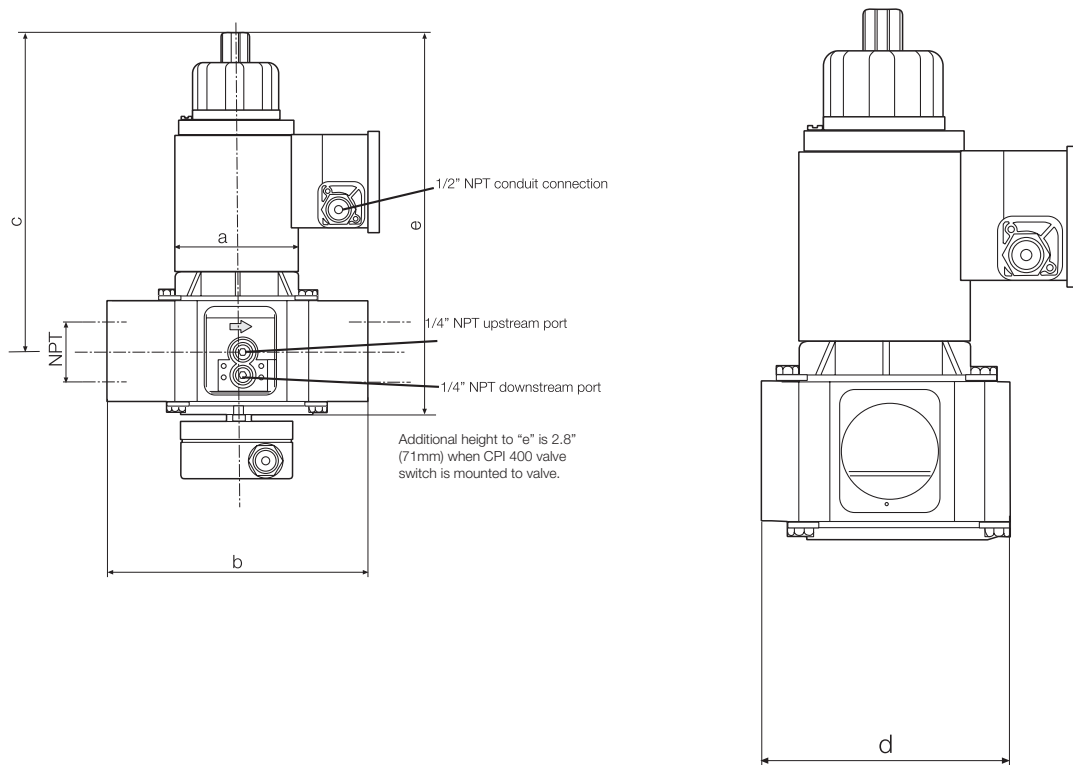

Functional description (Reference page 3)

The MVD and MVDLE series valves are automatic safety shutoff valves. The electromagnetic drive opens against the force of the closing spring 4.

For the MVD and MVDLE series, the main flow through valve can be limited by the maximum flow adjustment 8.

On the MVDLE series, the hydraulic brake 10 permits slow opening. Initial lift can be adjusted 9. If power is interrupted (operating voltage), closing spring 4 closes the valve within 1 second.

The valve position can be visually monitored by using the field installed visual indicator (VI) 12, or it can be visually

and electronically monitored by a field installed CPI 400, which includes valve position indication lamps and one SPDT interlock switch 11 (order separately).

PRESSURE DROP FOR OTHER GASES

To determine the pressure drop when using a gas other than natural gas, use the flow formula below and f value located in the chart below to determine the “corrected” flow rate in CFH through the valve for the other gas used. For example, when using propane, divide the volume (CFH) of propane required for the application by the calculated value f (f = 0.66 for propane). Use this “corrected” flow rate and the flow curve on the next page to determine pressure drop for propane.

$$\dot{V}_{\text{gas used}} = \dot{V}_{\text{Natural Gas}} \times f$$

f = correction factor to determine flow through valves with other gases.

$$f = \sqrt{\frac{\text{Spec. gravity of Natural Gas}}{\text{Spec. gravity of gas used}}}$$

Type of gas	Density [kg/m ³]	sg	f
Natural gas	0.81	0.65	1.00
Butane	2.39	1.95	0.58
Propane	1.86	1.50	0.66
Air	1.24	1.00	0.80

**Safety Shutoff Valves
MVD/6 and MVDLE/6**



Flow curve

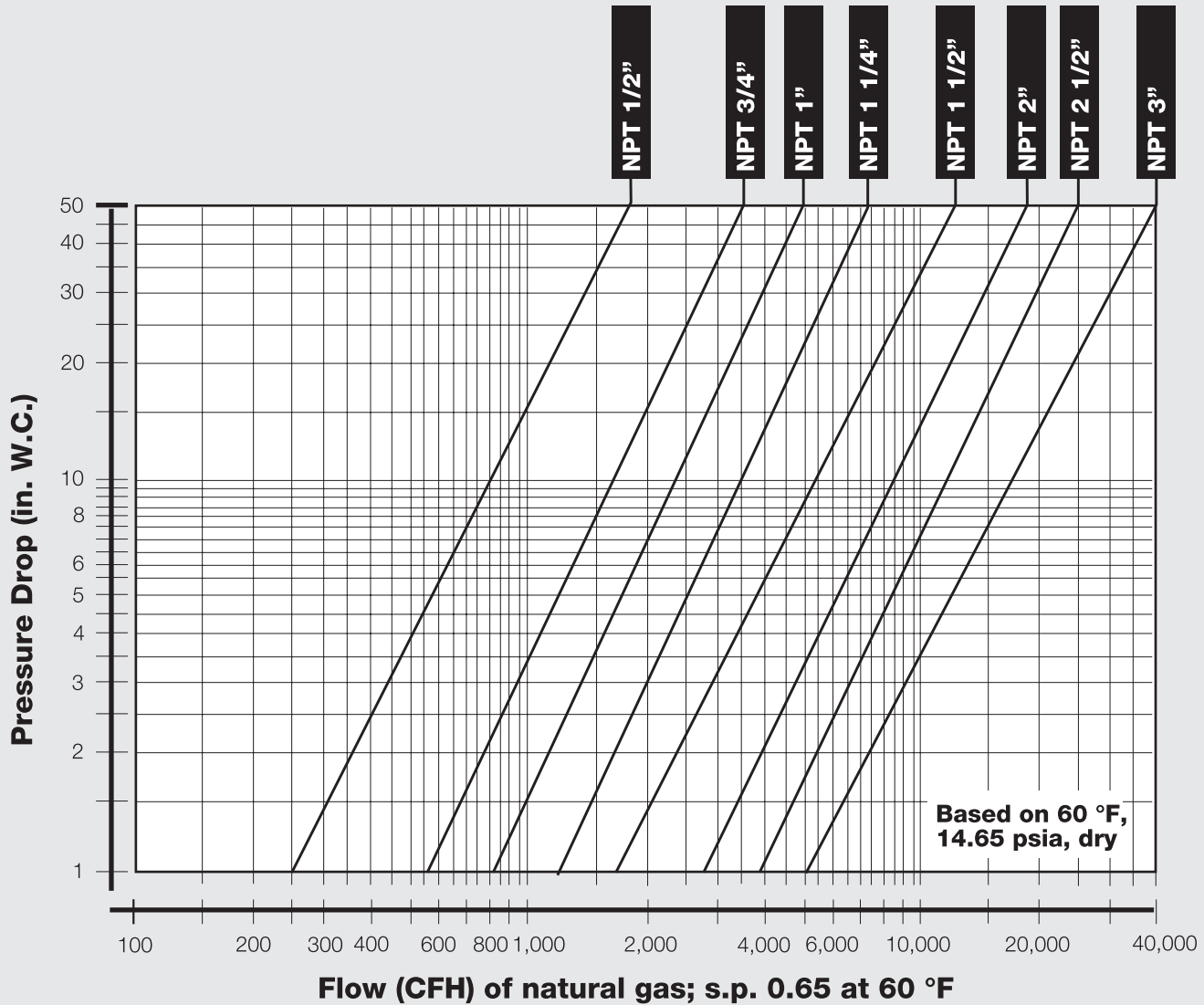

We reserve the right to make any changes in the interest of technical progress.

Karl Dungs Inc.
 524 Apollo Drive, Suite 10
 Lino Lakes, MN 55014, U.S.A.
 Phone 651 792-8912
 Fax 651 792-8919
 e-mail info@karldungsusa.com
 Internet <http://www.dungs.com/usa/>

Karl Dungs GmbH & Co. KG
 P.O. Box 12 29
 D-73602 Schorndorf, Germany
 Phone +49 (0)7181-804-0
 Fax +49 (0)7181-804-166
 e-mail info@dungs.com
 Internet <http://www.dungs.com>