

Dual Modular Safety Shutoff Valves with Proof of Closure

DMV-D/622 Series
DMV-DLE/622 Series

DUNGS[®]
Combustion Controls



Two normally closed automatic shutoff valves in one housing. Valve 2 (V2) incorporates “proof of closure”. Each valve has the following approvals.

UL Recognized

- UL 429
- File #MH16727

CSA Certified

- ANSI Z21.21
- CSA 6.5
- Marked C/I
- File # 157406

FM Approved

- Class 7411
- File # J.I. 3004006

Commonwealth of Massachusetts Approved Product

- Approval code G1-1107-35
- Gas Safety Shutoff Valve

US and Canadian Models

- DMV-D 702/622 and 703/622
- DMV-DLE 702/622 and 703/622
- 1/2 in. NPT - 2 in. NPT

Codes and Standards

This product is intended for installations covered by but not limited to NFPA 86, NFPA 37, NFPA 160, ANSI Z83.4/ CSA 3.7, ANSI Z83.18/CSA 4.9, ANSI Z21.13, CSD-1, UL 795, UL 2200, CAN1-3.1, CGA 3.2, CSA 3.8 or CSA B149.1 and CSA B149.3.

**DUNGS is an ISO 9001
manufacturing facility.**



Description

The Dual Modular Valve DMV/622 combines two automatic shutoff valves in one compact housing. Valve 2 (V2) incorporates “proof of closure” valve seal overtravel and interlock. Both valves can be wired independently or in parallel.

Valve 1 (V1) of the DMV-D and DMV-DLE series is fast opening and fast closing. Valve 2 (V2) of the DMV-D is fast opening, while V2 of the DMV-DLE is slow-opening for smoother light-off. Max. flow adjustment on V2 provides variable main flow on both models.

Internal profiles and compact design optimize flow and provide a low pressure drop. Two body styles reduce inventory. Directly mounting the following acces-

sories creates a compact valve train without additional piping:

- Pressure regulator
- High and low gas pressure switches
- Valve proving system
- Butterfly control valve

Application

The DMV/622 is recommended for industrial and commercial heating applications that require two safety shutoff valves and “proof of closure” valve seal overtravel and interlock. The DMV Dual Modular Valve is suitable for dry natural gas, propane, butane, air and inert gases.

A “dry” gas has a dew point lower than +15 °F and its relative humidity is less than 60 %.

DMV-D/622 Two normally closed automatic shutoff valves in one housing. Valve 2 (V2) incorporates “proof of closure”. V1 and V2 are fast opening, fast closing. Adjustable max flow with V2.

DMV-DLE/622 Two normally closed automatic shutoff valves in one housing. Valve 2 (V2) incorporates “proof of closure”. V1 fast opening, fast closing. V2 is slow opening, fast closing. Adjustable max flow and adjustable initial lift with V2.

Specifications

Body sizes	DMV 701	DMV 702	DMV 703
Pipe size / Thread	1/2" - 1" NPT	1" - 2" NPT	1" - 2" NPT
Max. operating pressure	7 PSI (500 mbar) UL, FM	5 PSI (360 mbar) CSA	
Max. body pressure	15 PSI (1000 mbar)		
Max. close off pressure	7 PSI (500 mbar) UL, FM	5 PSI (360 mbar) CSA	
Electrical ratings (+10 % / -15 %)	110 - 120 VAC @ 50 - 60 Hz 24 VAC @ 50 - 60 Hz; 24 VDC		
Power ratings	DMV 701: 45 VA	DMV 702: 65 VA	DMV 703: 80 VA
	Ratings shown are total power consumption for both valves inclusive. Inrush and full load current have the same VA rating.		
Enclosure rating	NEMA Type 12		
Electrical connection	DIN-connector with 1/2" NPT conduit adapter		
Operating time	100 % duty cycle		
Closing time	< 1 s		
Opening time (to max. flow)	DMV-D.../622 DMV-DLE.../622	V1 & V2 < 1 s V1 < 1 s; V2 Adjustable to approx. 10 to 20 s at 70 °F	
Initial lift adjustment	Adjustable on V2	DLE only; approx. 0 to 70 % of total flow	
Max. flow adjustment	Adjustable on V2	approx. 5 to 100 % of total flow	
Materials in contact with gas	Housing: Aluminium, Steel Sealings on valve seats: NBR-based rubber		
Ambient temperature rating	-40 °F to +150 °F (-40 °C to +65 °C)		
Installation position	Safety shutoff valve from vertically upright to horizontal		
Gas filter (optional)	Replaceable integral gas filter (50 micron) in inlet of DMV or Pre-Mount Filter Block for DMV 702 and 703. (Cannot be used with FRI directly mounted to the DMV)		
Gas strainer (standard)	Installed in the housing upstream V1 (23 mesh)		
Proof of closure switch Factory mounted and calibrated	SPDT switch with indication lamps;	AC max. 10A resistive @ 120 VAC AC max. 8A inductive @ 120 VAC	
Position indication	Visual indicator (VI)		
Test ports / Pressure switch mounting ports	G 1/8 ISO 228 ports available on both sides. Each side has one port upstream V1, one between V1 and V2, one downstream V2, and one on each flange.		
Valve proving system	Requires VPS 504; mounts directly to either side of DMV		

DMV dual safety shutoff valve modular system

Optional mounting system shown,
other configurations possible

DMV dual safety shutoff valve with upstream FRI pressure regulator

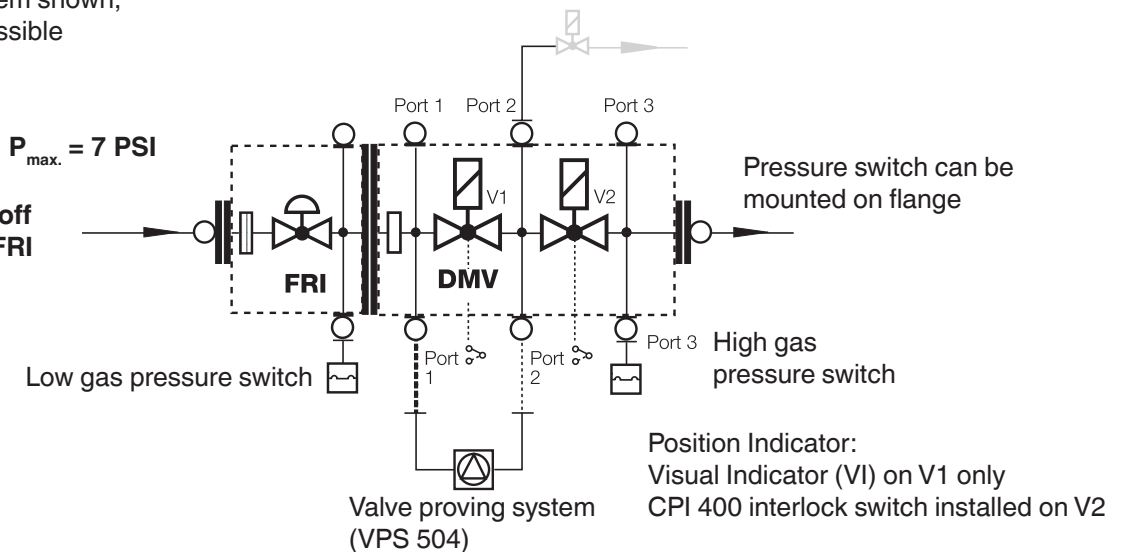

DMV dual safety shutoff valve with downstream FRI pressure regulator

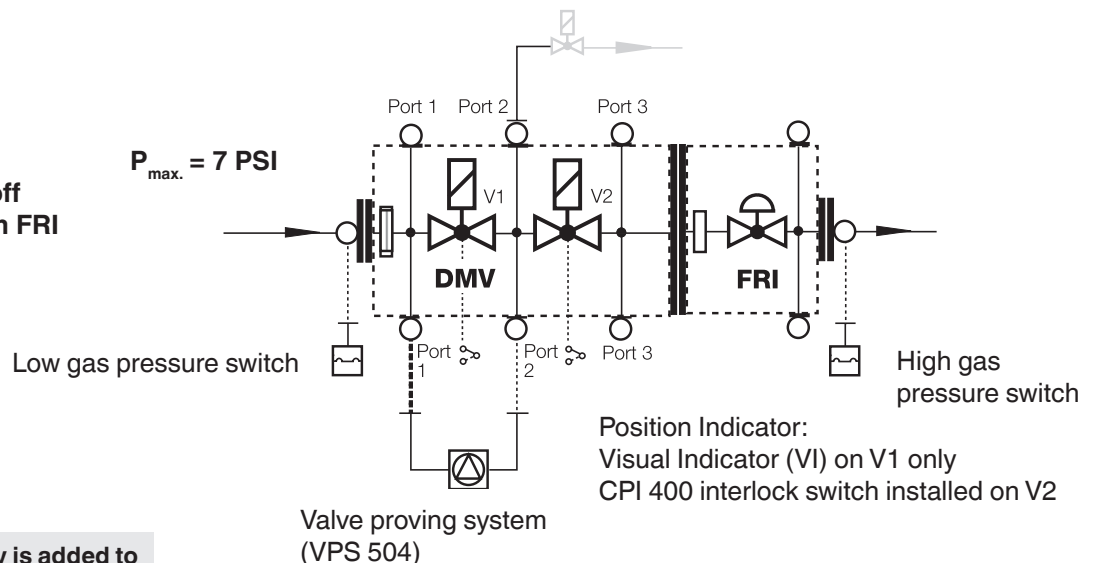

! When an accessory is added to the DMV, it may not be possible to mount other devices.

FRI Gas pressure regulator

Mounting the FRI series gas pressure regulator directly to the DMV dual safety shutoff valve is possible with a mounting kit.

The FRI pressure regulator can be installed upstream or downstream of the DMV dual safety shutoff valve depending on application requirements.

FRI mounting kit for DMV

FRI 705 - 707/6 to DMV 701/622

Order No. 219 967

FRI 710-712/6 to DMV 702/622 + DMV 703/622

Order No. 219 968

Additional Accessories

VPS 504

Valve proving system (approved by some authorities having jurisdiction in lieu of vent valve and "proof of closure" e.g. FM, IRI).

Integral gas filter (optional)

50 micron gas filter

Pre-Mount Filter (optional)

50 micron gas filter

GAO/GMH/GML A2

gas pressure switch

Position indication

Visual indicator (VI)

DMK butterfly control valve

Mounts directly downstream of DMV to modulate gas flow. Requires actuator. Use DMA actuator with DMK butterfly valve.

DMV D(LE) 7xx/622 VLA (with vent line adapter)

Factory installed vent line adapter which integrates a vent line connection with the DMV series.

Adapters

- 1/4" NPT adapter (225-047)
- 1/2" NPT Pilot gas adapter; Check flow requirements. (225-043)
- G 1/8" Test nipple (219-008)
- Port 3 Pressure switch mounting adapter (214-975)

Dimensions inch (mm)

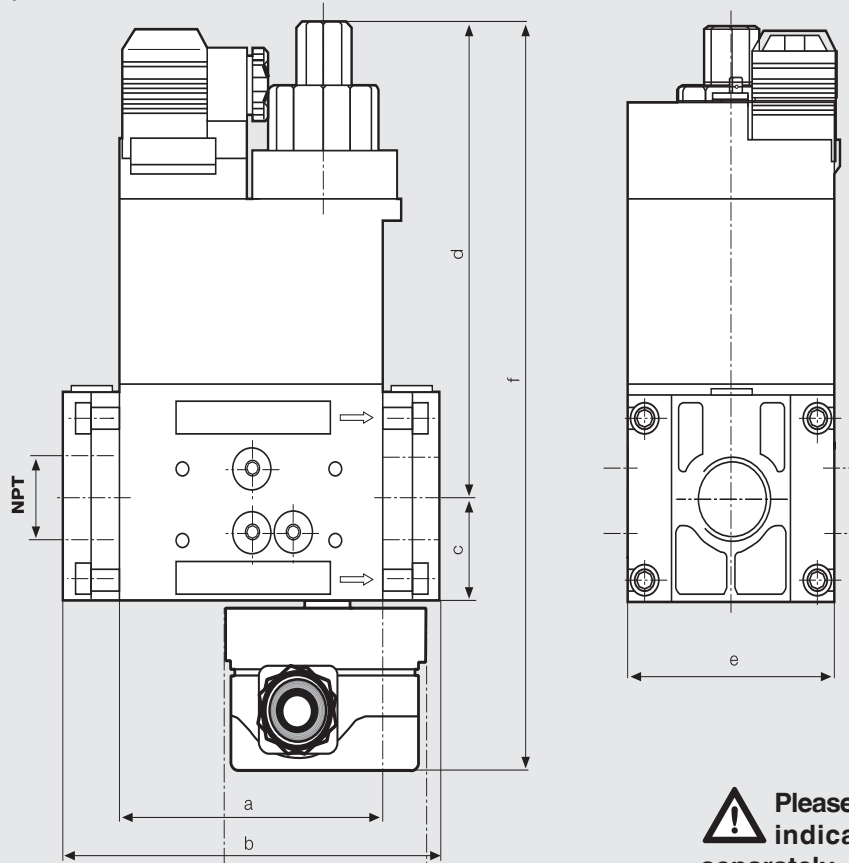

⚠ Please order flanges, position indicators and gas filters separately

Type	110-120 VAC @ 50-60 Hz Order No.	24 VAC 50-60 Hz Order No.	24 VDC Order No.	Power* [VA]	Dimensions [inch] Dimensions [mm]						Weight [lbs] [kg]
					a	b**	c	d	e	f	
DMV-D 701/622	243-761P	upon request	upon request	45	3.7 93	5.6 141	1.4 35	1.4 35	1.4 35	4.6 2,1	4.6 2,1
DMV-D 702/622	230-791P	upon request	upon request	65	4.9 124	6.9 / 7.9 174 / 201	1.8 45	5.9 150	3.9 101	10.4 263	10.1 4,6
DMV-D 703/622	230-793P	upon request	upon request	80	4.9 124	6.9 / 7.9 174 / 201	1.8 45	7.5 190	3.9 101	12.0 303	12.1 5,6
DMV-DLE 701/622	244-000P	upon request	upon request	45	3.7 93	5.6 141	1.4 35	5.9 160	2.9 73	4.6 2,1	4.8 2,2
DMV-DLE 702/622	230-792P	upon request	upon request	65	4.9 124	6.9 / 7.9 174 / 201	1.8 45	6.7 179	3.9 101	11.2 310	10.3 4,7
DMV-DLE 703/622	230-794P	upon request	upon request	80	4.9 124	6.9 / 7.9 174 / 201	1.8 45	8.6 218	3.9 101	13.1 331	12.3 5,7

* Inrush current and full load current have the same VA rating.

** DMV 702/703 with 1" or 1 - 1/4" flange: 6.9" / DMV 702/703 with 1 - 1/2" or 2" flange: 7.9"

Valve Description	Flange	NPT	Rp
DMV-701/602	1/2"	222-371	222-341
DMV-701/602	3/4"	222-368	222-342
DMV-701/602	1"	221-999	222-001
DMV-702/6 & 703/602	1"	222-369	222-343
DMV-702/6 & 703/602	1 1/4"	222-370	222-344
DMV-702/6 & 703/602	1 1/2"	222-003	221-884
DMV-702/6 & 703/602	2"	221-997	221-926

DIN-Connector	210-319
Visual indicator	217-665

Integral gas filter (50 micron)	P/N
DMV-701/602	214-276
DMV-702/602	214-525
DMV-703/602	214-525

Pre-Mount Filter	P/N
DMV-701/602	232-440
DMV-702/602	226-342
DMV-703/602	226-342
Pre-Mount replacement filter	P/N
DMV-701/602	238-653
DMV-702/602	226-997
DMV-703/602	226-997

DMV-D(LE).../622
sectional drawing

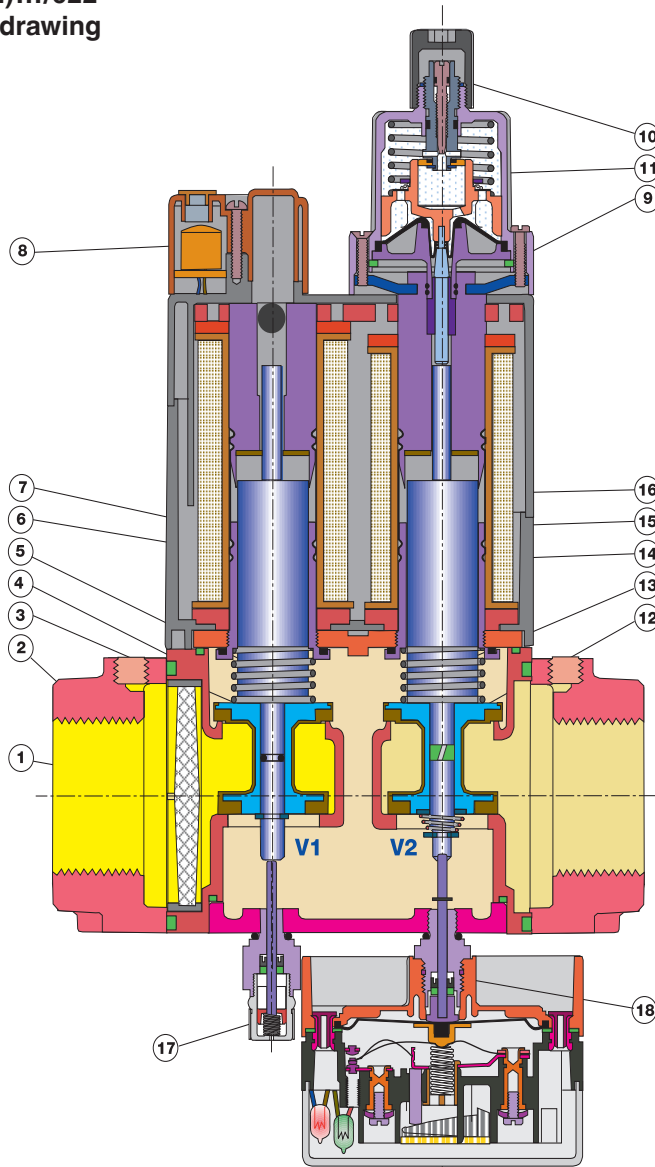

- 1 Strainer
- 2 Flange
- 3 Valve V1
- 4 Housing
- 5 Closing spring V1
- 6 Plunger V1
- 7 Solenoid V1
- 8 Electrical connection
- 9 Max flow adjustment
- 10 Initial lift adjustment (DMV-DLE)
- 11 Hydraulic brake (DMV-DLE)
- 12 Valve V2
- 13 Closing spring V2
- 14 Plunger V2
- 15 Solenoid V2
- 16 Solenoid housing
- 17 Visual indicator (VI)
- 18 Proof of closure switch

Pressure drop for other gases

To determine the pressure drop when using a gas other than natural gas, use the flow formula below and f value located in the table below to determine

the “corrected” flow rate in CFH through the valve for the other gas used. For example, when using propane, divide the volume (CFH) of propane required for the application by the calculated value

f (f = 0.66 for propane). Use this “corrected” flow rate and the flow curve on the next page to determine pressure drop for propane.

Determining equivalent flow through valves using another gas

$$\dot{V}_{\text{gas used}} = \dot{V}_{\text{Natural gas}} \times f$$

$$f = \sqrt{\frac{\text{Density of Natural gas}}{\text{Density of gas used}}}$$

Type of gas	Density [kg/m ³]	s.g.	f
Natural gas	0.81	0.65	1.24
Butane	2.39	1.95	0.58
Propane	1.86	1.50	0.66
Air	1.24	1.00	1.00

**Dual Modular Safety
Shutoff Valves
with Proof of Closure**

**DMV-D/622 Series
DMV-DLE/622 Series**



Flow curve

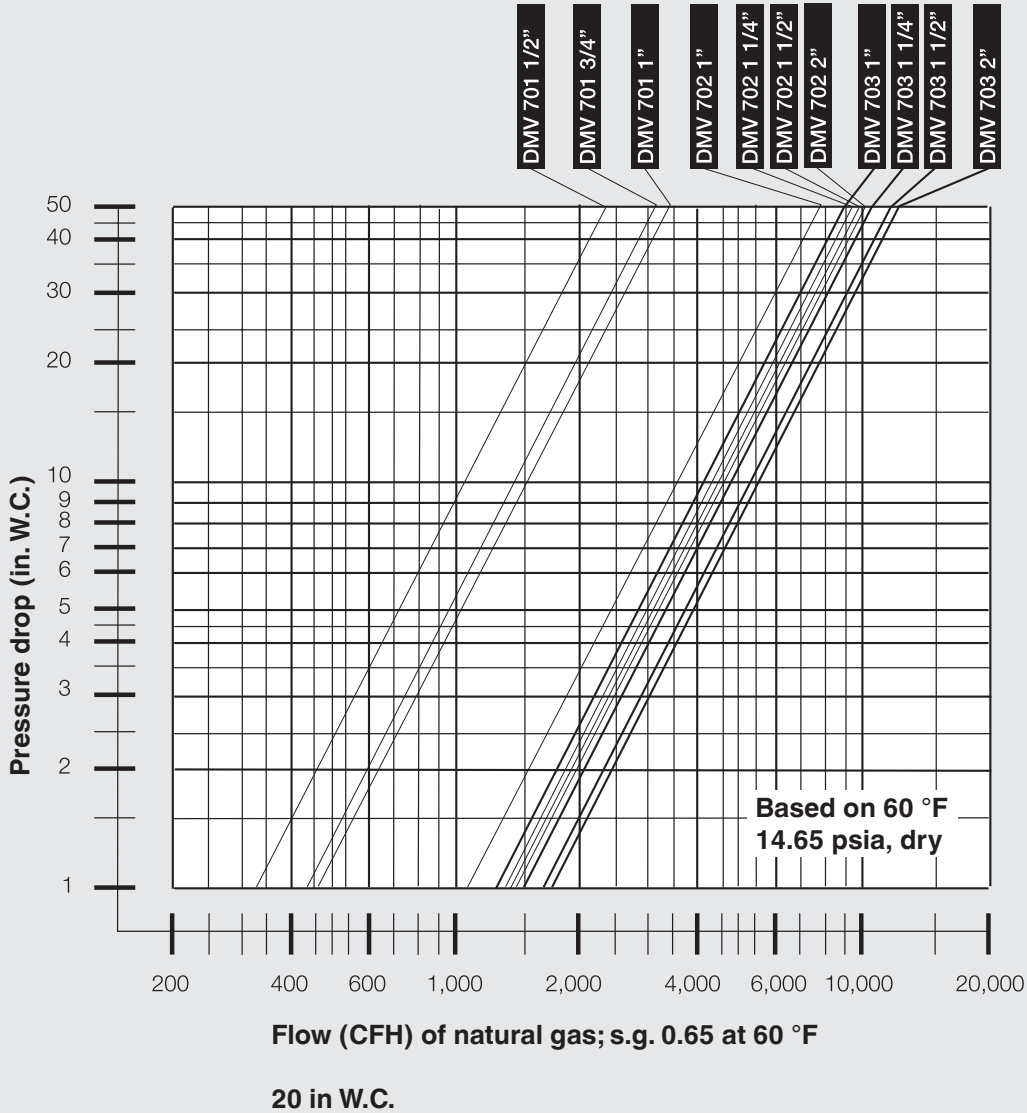

We reserve the right to make any changes in the interest of technical progress.

Karl Dungs Inc.
3890 Pheasant Ridge Drive NE
Suite 150
Blaine, MN 55449, U.S.A.
Phone 763 582-1700
Fax 763 582-1799
e-mail info@karldungsusa.com
Internet <http://www.dungs.com/usa/>

Karl Dungs GmbH & Co. KG
P.O. Box 12 29
D-73602 Schorndorf, Germany
Phone +49 (0)7181-804-0
Fax +49 (0)7181-804-166
e-mail info@dungs.com
Internet <http://www.dungs.com>